



PIATTAFORMA AEREA
TELESCOPICA con JIB articolato

Telescopic Aerial Platform w/articulated JIB

SCJ
18 H
7,5 t

MOUNTED ON



STANDARD
VERSION

IVECO

IVECO DAILY



MERCEDES
ATEGO

**ALSO AVAILABLE ON ANY TRUCK
OF YOUR CHOICE**

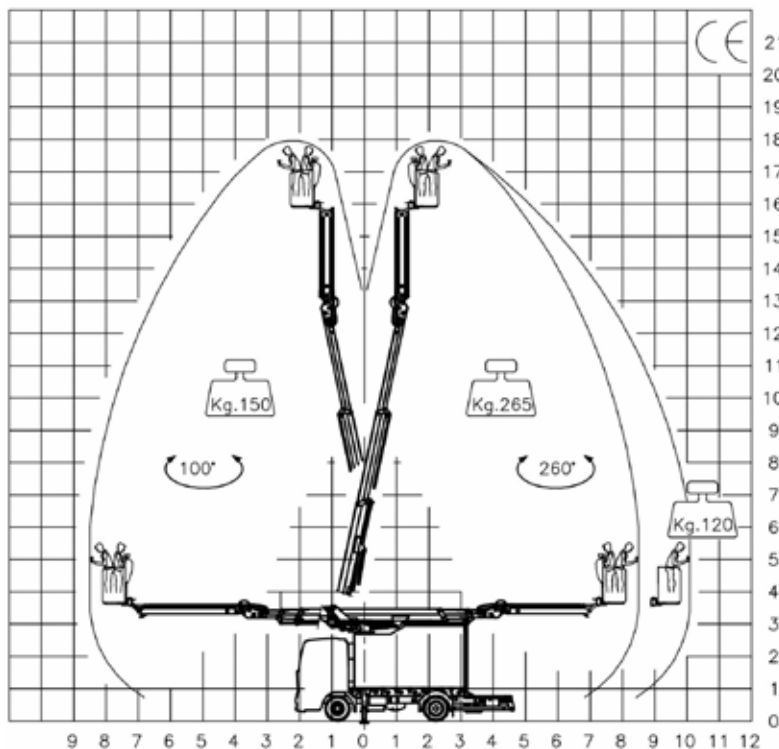
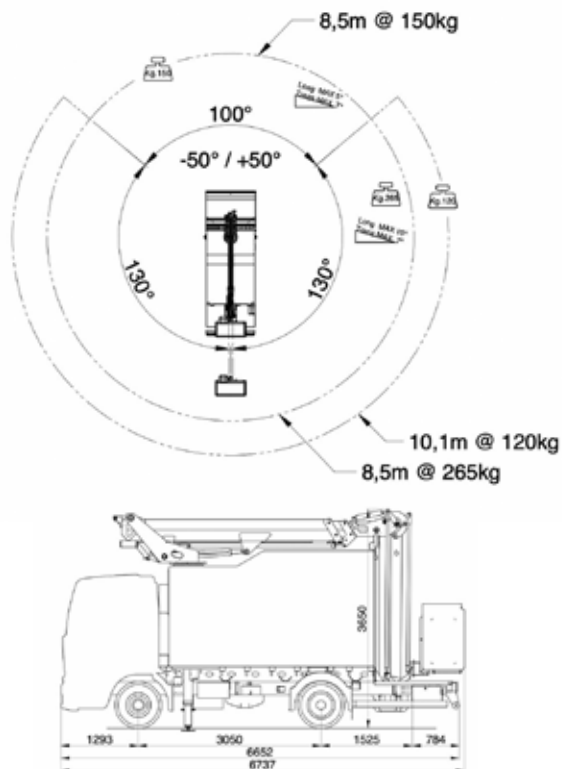

IT - SCJ-18H è una piattaforma aerea telescopica con ultimo braccio snodato (JIB) studiata principalmente per i manutentori delle linee elettriche e telefoniche. Essa viene predisposta con un'ampia area di lavoro sul cassone, accessibile dallo stesso piano di ingresso navicella, per l'immagazzinamento di materiale di consumo o la riparazione dei componenti direttamente in loco. La stabilizzazione in sagoma a ruote a terra (H) permette il piazzamento in strade trafficate senza particolari ingombri, per interventi veloci sulle infrastrutture di interesse.

EN - SCJ 18H is a telescopic aerial platform with articulated JIB purposely designed and produced for electric and telephone grid maintainers. It features a reasonably sized working area on its load bed, which is accessible from the basket access platform, capable of storing materials and allow personnel to repair components directly on site. Its "in shape" stabilization, "rubber-on-the-ground" (H) permits its use on busy roads with no need for extra space, resulting on quick intervention on the interested infrastructures.

CARATTERISTICHE	FEATURES	SCJ18 H	CARATTERISTICHE GENERALI / TECHNICAL FEATURES
Max. altezza di lavoro	Max. working height	18,00 m	ITA PLE conforme alla direttiva macchine 2006/42/CE, secondo la norma EN 280:2015 EN PLE in conformity with EU machine directive 2006/42/CE, according to standard EN 280:2015
Max. altezza piano di lavoro	Max. platform height	16,00 m	ITA Cesta in vetroresina, isolata 1000V EN Fiberglass basket, 1000V insulation
Max. sbraccio laterale	Max. lateral outreach	10,2 m	ITA Comandi proporzionali EN Proportional controls
Carico nominale	Rated load	265 kg	ITA Avvio/Arresto motore dal cesto EN Stop/start engine from the basket
Dimensioni cesta	Basket dimensions	1,4x0,7x1,1m	ITA Pompa manuale di emergenza EN Emergency manual pump
Rotazione torretta	Turret rotation	360° ± 20°	ITA -15° / +15° area di lavoro posteriore, senza stabilizzatori EN -15° / +15° backward working area, without stabilisers
Rotazione cesta	Basket rotation	± 60°	ITA Livellamento automatico dal cesto EN Automatic stabilisers control from the basket
Escursione JIB	JIB excursion	- 90° / + 90°	ITA Sistemi di diagnostica (optional) EN Diagnostic system (optional)
Stabilizzazione	Stabilization	H	ITA Funzione "HOME" : rientro automatico in posizione di trasporto (optional) EN "Home function" for automatic return in transport position (optional)
P.T.T. min.	G.V.W.	7,5 T	

SCJ18 H
MADE IN ITALY

Safi Group S.r.l.
Via S. Rocco, 8,
31041 Cornuda - TV - ITALY
0039 0423 639321
info@safi.it
www.safi.it



ST2-SCJ18H_00_it-en