

## PIATTAFORMA AEREA TELESCOPICA con JIB articolato

Telescopic Aerial Platform w/ articulated JIB

**SCJ**  
**14 A**  
5,0 t



IVECO DAILY



VOLKSWAGEN CRAFTER

ALSO AVAILABLE ON WICHEVER VAN OF YOUR CHOICE

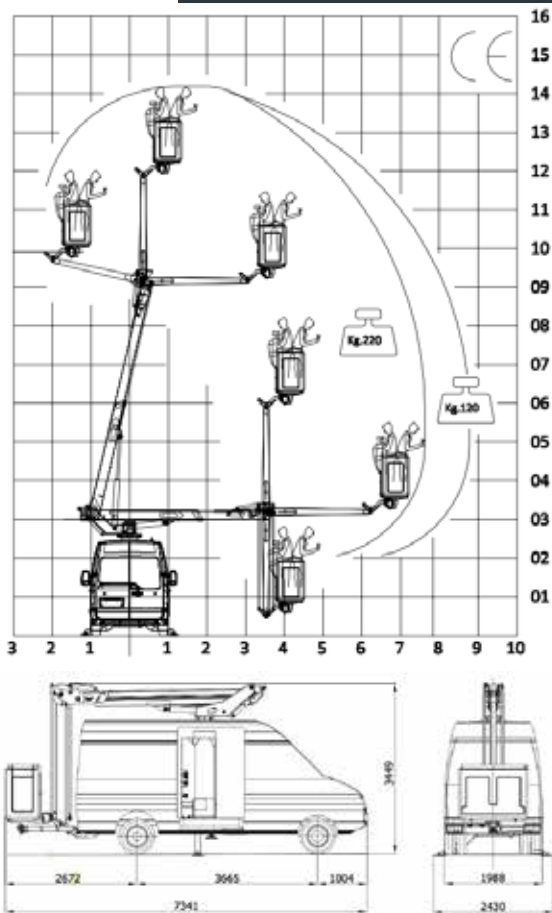
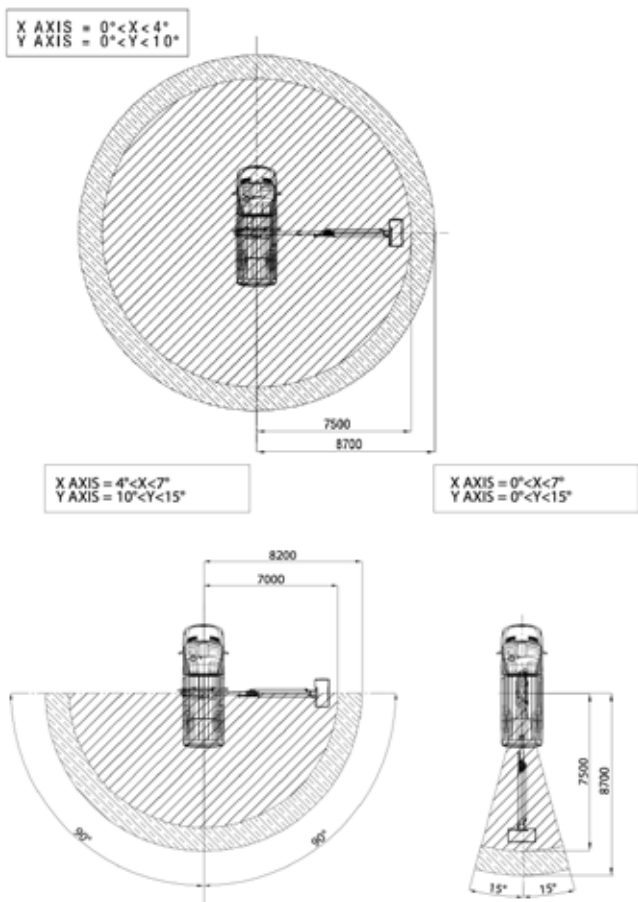

IT - SCJ14A è una piattaforma aerea telescopica con ultimo braccio snodato (JIB) montata su van, studiata principalmente per i manutentori delle linee elettriche e telefoniche. La sua predisposizione permette di sfruttare il cassone per l'immagazzinamento di materiale di consumo o la riparazione dei componenti direttamente in loco. La stabilizzazione in sagoma a ruote a terra (A) permette il piazzamento in strade trafficate senza particolari ingombri, per interventi veloci sulle infrastrutture di interesse.

EN - SCJ14A is a telescopic aerial platform with articulated JIB purposely designed and produced for electric and telephone grid maintainers. Its VAN predisposition allows to use the back room for storing materials and allow personnel to repair components directly on site. Its "in shape" stabilization (A) permits its use on busy roads with no need for extra space, resulting on quick intervention on the interested infrastructures.

CARATTERISTICHE	FEATURES	SCJ 14A	CARATTERISTICHE GENERALI / TECHNICAL FEATURES
Max. altezza di lavoro	Max. working height	14 m	ITA PLE conforme alla direttiva macchine 2006/42/CE, secondo la norma EN 280:2015 EN PLE in conformity with EU machine directive 2006/42/CE, according to standard EN 280:2015
Max. altezza piano di lavoro	Max. platform height	12 m	ITA Cesta in vetroresina, isolata 1000V EN Fiberglass basket, 1000V insulated
Max. sbraccio laterale	Max. lateral outreach	9,7 m	ITA Comandi proporzionali EN Proportional controls
Carico nominale	Rated load	220 kg	ITA Avvio/Arresto motore dal cesto EN Stop/start engine from the basket
Dimensioni cesta	Basket dimensions	1,4x0,7x1,1m	ITA Pompa manuale di emergenza EN Emergency manual pump
Rotazione torretta	Turret rotation	360° ± 20°	ITA -15° / +15° area di lavoro posteriore, senza stabilizzatori EN -15° / +15° backward working area, without stabilisers
Rotazione cesta	Basket rotation	± 90°	ITA Livellamento automatico dal cesto EN Automatic stabilisers control from the basket
Escursione JIB	JIB excursion	180°	ITA Sistemi di diagnostica (optional) EN Diagnostic system (optional)
Stabilizzazione	Stabilization	A	ITA Funzione "HOME" : rientro automatico in posizione di trasporto (optional) EN "HOME" function for automatic return to transport position
P.T.T. min.	G.V.W.	5,0 T	

