



# PIATTAFORMA DI TRASPORTO

Transport platform | Plate-forme de transport

# GAMMA

MC/PC

# GAMMA MC/PC

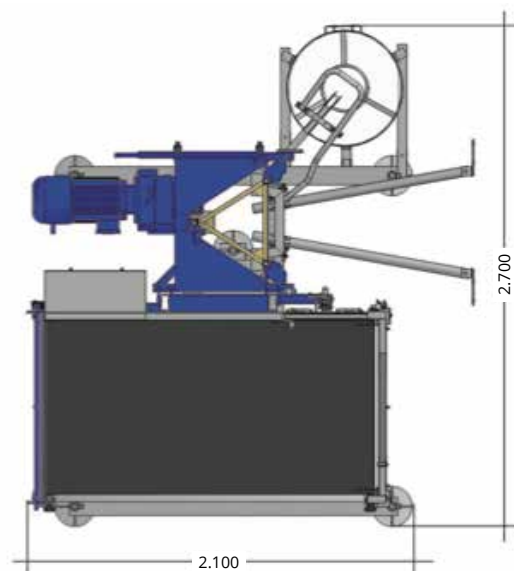

Traliccio triangolare - Triangular mast - Mât triangulaire

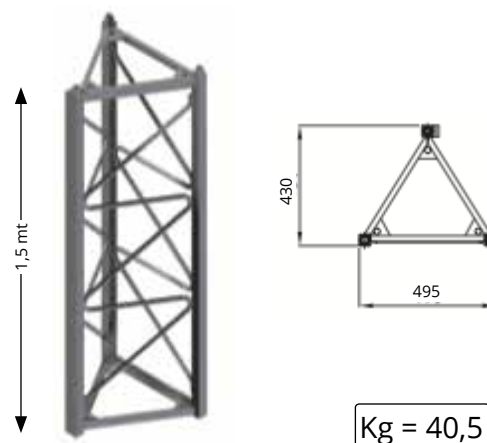

DATI TECNICI	TECHNICAL DATA	DONNEES TECHNIQUES	GAMMA MC/PC
Numero massimo di persone	Max number of personnel	Nombre de personnes admises	8
Portata max.	Max payload	Charge utile maximale	800 daN
Altezza max. colonna	Max column height	Hauteur maxi de la colonne	≈ 100 m
Interasse max. ancoraggi	Max distance between anchors	Entraxe maxi entre les ancrages	6,0 m
Dimensioni piano di carico (WxLxH)	Loading surface dimensions (WxLxH)	Dimensions de la surface de chargement (WxLxH)	1,80 x 1,00 x 1,10 m
Potenza nominale	Rated power	Puissance nominale	4,7 / 5,7 Kw
Alimentazione	Power supply	Alimentation électrique	220÷240 / 380÷420 Vac 50Hz
Corrente di spunto	Inrush current	Courant de démarrage	85 Amperes
Velocità di esercizio MC-PC	MC-PC operating speed	Vitesse de travail MC-PC	12 - 24 m/min

