



# MONTACARICHI DA CANTIERE

Material Hoist | Élévateur à crémallère

# VISION MC

# VISION MC

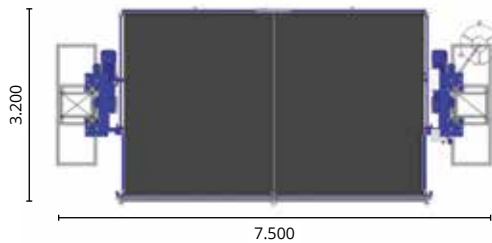

Traliccio piatto - Flat mast - Mât plat

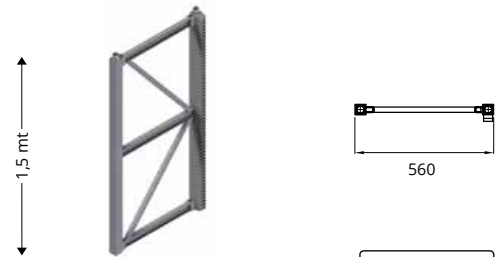

**Kg = 50**

Traliccio quadrato - Square mast - Mât carré

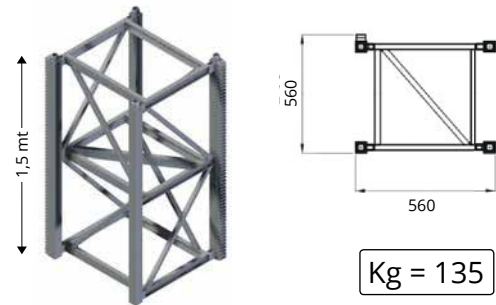

**Kg = 135**

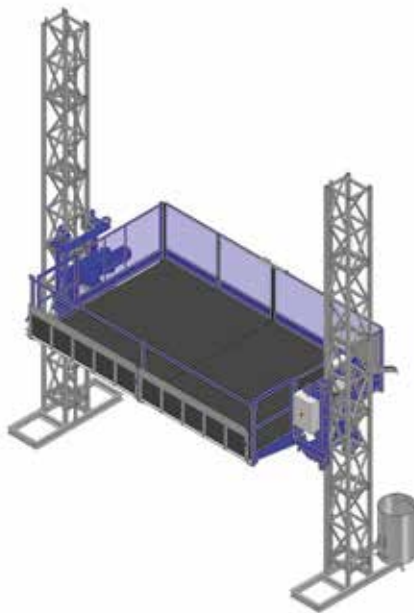

**NOTE:**

IT - Dati tecnici: La macchina può essere venduta anche nella versione per solo materiale - MONTACARICHI;  
 EN - Technical data: the machine can be sold even for material only - MATERIAL HOIST;  
 FR - Caractéristiques techniques: La machine peut être vendue dans une version pour seul matériel - MONTE-MATÉRIAUX;

DATI TECNICI	TECHNICAL DATA	DONNEES TECHNIQUES	VISION MC		
			1500	3000	5000
N° di colonne	Number of masts	Nombre de mâts	1	2	2
Portata max.	Max payload	Charge utile maximale	1500 daN	3000 daN	5000 daN
N° massimo di passeggeri	Max n° of passengers	N° de passagers admises	8		
Altezza max. colonna	Max column height	Hauteur maxi de la colonne	≈200m		
Interasse max. ancoraggi	Max distance between anchors	Entraxe maxi entre les ancrages	9 m		
Dimensioni piano di carico (WxLxH)	Loading surface dimensions (WxLxH)	Dimensions de la surface de chargement (WxLxH)	3,00 x 1,50 x 1,10 m	3,00 x 3,00 x 1,10 m	5,00 x 1,50 x 1,10 m
Potenza nominale Inverter	Frequency converter rated power	Inverter puissance nominale	5,5 Kw	2x5,5 Kw	2x7,5 Kw
Alimentazione	Power supply	Alimentation électrique	220÷240 / 380÷420 Vac 50Hz		
Corrente di spunto	Inrush current	Courant de démarrage	67,5 A	135 A	185 A
Velocità di esercizio MC-PC	MC-PC operating speed	Vitesse de travail MC-PC	24,0 m/min		

