



ASCENSORE DA CANTIERE PER PERSONE E COSE

Passenger and material hoist | Ascenseur de chantier
pour personnes et matériaux

SCAF
AS

SCAF AS

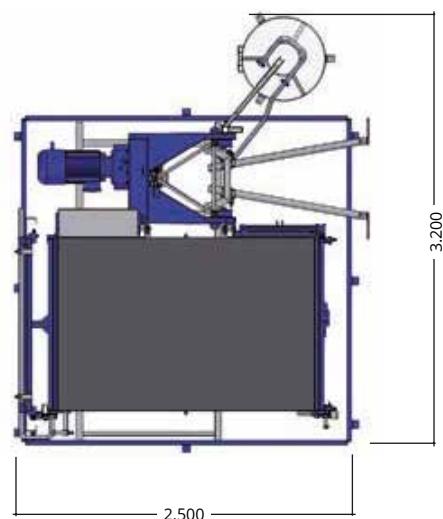

Traliccio triangolare - Triangular mast - Mât triangulaire

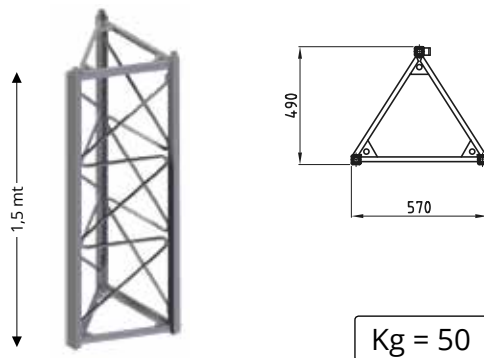

| DATI TECNICI | TECHNICAL DATA | DONNEES TECHNIQUES | SCAF AS |
|------------------------------------|------------------------------------|--|-------------------------------|
| Portata max. | Max payload | Charge utile maximale | 1.000 daN |
| N° massimo di passeggeri | Max n° of passengers | N° de passagers admises | 10 |
| Altezza max. colonna | Max column height | Hauteur maxi de la colonne | ≈180m |
| Interasse max. ancoraggi | Max distance between anchors | Entraxe maxi entre les ancrages | 6 m |
| Dimensioni piano di carico (WxLxH) | Loading surface dimensions (WxLxH) | Dimensions de la surface de chargement (WxLxH) | 1,30 x 2,00 x 2,10 m |
| Ingombro a terra | Ground dimension | Dimension de la base | 2,50 x 3,20 m |
| Potenza nominale | Rated power | Puissance nominale | 2 x 5,5 Kw |
| Alimentazione | Power supply | Alimentation électrique | 220÷240 / 380÷420 Vac 50Hz |
| Corrente di spunto | Inrush current | Courant de démarrage | 135 A |
| Velocità di esercizio | Operating speed | Vitesse de travail | 30,0 m/min |

